

**GRAIN VALLEY R-5 SCHOOL DISTRICT
FOOD SERVICE DEPARTMENT
Grain Valley North Middle School
31608 E Pink Hill Rd
Grain Valley, MO 64029
816-994-4812**

April 3, 2024

Vendor Representative:

The Grain Valley School District is currently seeking bids for Delfield serving counters and equipment for Grain Valley High School. Please read specific details in the enclosed forms for the bidding process. All bidding conditions, specifications, and bid forms are enclosed for your consideration.

The deadline for submitting sealed bids is Thursday, April 18th, 2023, at 2 p.m. CST with the formal bid opening at 2:05 PM in the food service conference room at Grain Valley North Middle School. Bids must be sealed and bidder must indicate “Grain Valley High School Kitchen Remodel” on the outside of the envelope. If the bid is not received by the stated deadline, the bid will not be considered and will be returned unopened.

The contract award will be made on Friday April 19th, 2024. Following the contract award, the details of delivery, billing, ordering, and any other terms of business will be determined in a meeting with those persons directly involved.

If there are any questions, please contact me. I am looking forward to receiving your bid.

Sincerely,

Andy Hughes, Food Services Director
31608 E Pink Hill Rd
Grain Valley, MO 64029
Ph: 816-994-4812
ahughes@gvr5.net
Office Hours: Monday-Friday 7 a.m. – 3 p.m.

GRAIN VALLEY R-5 SCHOOL DISTRICT

FOOD SERVICE BIDS STANDARD TERMS AND CONDITIONS

The following terms and conditions shall prevail, unless otherwise modified by the Grain Valley R-5 School District (GVSD), within this bid document. GVSD reserves the right to reject any bid which takes exceptions to these terms and conditions.

1. **Accuracy of bid:** Each bid is publicly opened and is made part of the public record of the Grain Valley school district. Therefore, it is necessary that any and all information presented is accurate. If there is a discrepancy between the unit price and extended total, the price advantageous to the Grain Valley School District will prevail.
2. **Late bids and modifications or withdrawals:** Bids received after the deadline designated on the vendor cover letter will not be considered and will be returned unopened.
3. **New supplies or equipment:** Unless otherwise specified, all materials, supplies or equipment offered by a bidder shall be new, unused or of recent manufacture and suitable for their intended purpose. All equipment shall be assembled and fully serviced, and ready for operation when delivered.
4. **Warranty:** Supplies or services furnished as a result of this bid shall be covered by the most favorable commercial warranties, expressed or implied, that the bidder and/or manufacturer gives to any customer. The rights and remedies provided herein are in addition to and do not limit any rights afforded to Grain Valley R-5 School District by any other clause of this bid, and reserves the right to request from bidders as separate manufacturer certification of all statements made in the proposal.
5. **Delivery terms:** All deliveries shall be f.o.b. destination and all freight charges shall be included in the bid price. Delivery is guaranteed by the bidder on all items for which a bid is submitted. Failure to deliver as guaranteed, or any other default by the bidder, may result in the disqualification of the bidder from future bidding.
6. **Damaged and/or late shipments:** GVSD has no obligation to accept damaged shipments and reserves the right to return at the vendor's expense damaged merchandise even though the damage was not apparent or discovered until after the receipt of the items. The vendor is responsible to notify the GVSD Food Services Department of any late or delayed shipments. GVSD reserves the right to cancel all or any part of an order if the shipment is not made as promised. Cost of all returns shall be the responsibility of the successful bidder.
7. **Seller's invoice:** Invoices shall be prepared and submitted in duplicate to the school food production site. Invoices shall contain the following information: purchase order number; contract number; item number; description of supplies, or services; unit sizes of measure; quantity; unit price; extended totals; and total dollar amount of all products delivered. This invoice must accompany each delivery and remain at the school for proper disposition. Surcharges for transportation, fuel, and all other fees are to be included in the total bid cost. No additional charges will be considered after the bid has been submitted.
8. **Safety:** All practices, materials, supplies, and equipment shall comply with the Occupational Safety and Health Act (OSHA), as well as any pertinent federal, state, and/or local safety or environmental codes.
9. **Hold harmless:** The contractor agrees to protect, defend, indemnify and hold the board of education, its' officers, employees and agents free and harmless from and against any and all losses, penalties, damages,

settlements, costs, charges, professional fees or other expenses or liabilities of every kind and character arising out of or any causes of action of every kind and character in connection with or arising directly or indirectly out of this agreement and/or the performance hereof.

10. **Law governing:** All contractual agreements shall be subject to, governed by, and construed according to the laws of the state of Missouri.
11. **Contract provision:** The bidder certifies that neither it nor any of its principals (i.e. key employees) has been proposed for debarment, debarred, or suspended by a federal agency. The prospective bidder shall provide immediate written notice to the person to which this proposal is submitted at any time the prospective bidder learns that its certification was erroneous when submitted or has become erroneous by reason of changed circumstances.
12. **Non-discrimination clause:** No bidder on this request shall in any way, directly or indirectly, discriminate against any person because of age, race, color, handicap, sex, national origin, or religious creed.

GRAIN VALLEY R-5 SCHOOL DISTRICT

DETAILED SPECIFICATIONS AND SPECIAL CONDITIONS

1. **Contract scope:**

This contract is intended to cover the purchase, delivery, and installation of Delfield serving counter equipment for daily use at Grain Valley High School. 551 SW Eagles Pkwy, Grain Valley, MO 64029

2. **Work stoppages:**

The bidder guarantees delivery to the district regardless of any organized work stoppages.

3. **Delivery methods:**

The successful bidders' facilities and delivery vehicles must conform to local HACCP, state, and federal rules and regulations regarding sanitation and are subject to inspection by district or other officials at the discretion of the district.

The bidder's driver will deliver and off-load all products to a specified area at Grain Valley High School. The contractor shall provide any equipment needed to complete this process. Unloading and placing of the materials and supplies is the responsibility of the successful bidder and the district accepts no responsibility for unloading and placing of these materials or supplies. Any costs incurred due to the failure of the bidder to comply with this requirement will be charged to the bidder. No help for unloading and/or placement of materials and/or supplies will be provided by the district and bidders should notify their truckers accordingly.

At the time of delivery, a designated district employee shall sign the invoice. This signature will only indicate that the order has been received, but will not indicate that the invoice has been reconciled to the actual items delivered. The district reserves the right to inspect delivered goods. If the goods cannot be inspected at the time of delivery, the bidder shall abide by the results of an inspection at a later time. The successful bidder agrees that any discrepancies will receive prompt attention and correction.

The district reserves the right to refuse payment on any unsigned invoice. The reconciliation will occur the same day and any deviations will be reported to the supplier's account representative who will then take the necessary steps to issue credit memos for any incorrect charges and arrange for the return of any shipping errors or deficient products. Missing product will be brought out to the district the next business day at the sole expense of the successful bidder. Any discrepancies will be clearly indicated and initialed by both parties.

4. **Order size:**

There shall be no extra charge to the district for any delivery made.

5. **Delivery failure:**

If the successful bidder fails to deliver an order, or part of an order, the supplier will take corrective action by either making a special delivery to the district, or by arranging for delivery by another vendor. The bidder shall assume any additional costs between the price of originally ordered item and the price from the alternate vendor.

6. **Invoices:**

All orders will be accompanied by an itemized invoice, in duplicate, including the unit name & account number, product name, unit cost, extension, piece count, and total charges.

7. **Payment:**

Payment is processed using the paperwork provided at the time of delivery. Statements of purchase must be provided by the vendor. All invoices are processed by the calendar month and submitted to the Board of Education for approval by the 3rd week within each calendar month.

8. **Tax exemptions:**

The district is exempt from various federal, state, and local taxes.

9. **Contract award:**

The district reserves the right to reject any or all bids, waive any informalities in the bids received and to award the bid on the basis of any single bid or any combination of bids that best conform to the bid conditions and specifications, and will be most advantageous to the district, price, and other factors considered.

Local bidders within 75 miles of Grain Valley High School will be given preference when evaluating the bids. All other factors including, but not limited to, service, accuracy, price, and other amenities will also be considered when evaluating bids. The district reserves the right to reject any or all bids based solely on district evaluation and to waive any technicalities. This does not obligate the district to pay any cost incurred by vendors related to submission of proposals in response to this request for bids.

Any award made as a result of this solicitation, may not be transferred, assigned, sub-contracted, mortgaged, pledged, or otherwise disposed of or encumbered in any way by the bidder.

After the district awards the bid, the winning bidder must be willing to meet in person at Grain Valley High School with CSI and Kain McArthur to sign off on all drawings. Drawings must be signed within seven business days after bid has been awarded.

Grain Valley High School Serving Counter Specifications

Equipment Bidder referred to as “KEC” in these specifications to provide the Delfield Serving Counter as specified below.

Alternate brands will not be accepted. New Delfield serving counter specified below to be provided per specifications below.

Serving counter line including counters 1A, 2A, 3A, 4A, 5A, 6A, 7A, 9, 10, 11 and 13 per the following specifications and drawing number 1848106_001A.

Serving counter D1 to be a quantity of (1) each and be provided per Delfield SKU 000-20113M0A1D and be 92” wide x 34.62” deep x 36” high. Counter area to be 14 gauge stainless steel surface and have tray slide on student side and work shelf on operator side. Tray slide to be constructed of solid surface corian (Color Selection Noted on Approval Drawing). Tray slide mounted at 34” high. Operator shelf to be stainless steel and fold down without tools and mounted at 36” high. Counter provided with 2 Tier FlexiTop designed to hold 4 full size sheet pans and operate as hot or frost top. Counter also provided with 1042G built in 2 well, FlexiWell style wells that can operate hot, cold, or freeze temperatures. Counter provided with 2 tier tempered glass sneezeguard above FlexiTops and Delfield DCFSFS adjustable style FlexiShield above FlexiWells all per Delfield drawing. Counter provided with laminate base, standoff panels and LED lighting with sneezeguard and under nosing of counter. Louvers to be powder coated, color noted on Delfield approval drawing. Counter provided on adjustable height casters with stainless steel toe kick on student side and left side.

Serving counter D2 to be a quantity of (1) each and be provided per Delfield SKU 000-20113MA0AZ and be 50” wide x 34.62” deep x 36” high. Counter area to be 14 gauge stainless steel surface and have tray slide on student side and work shelf on operator side. Tray slide to be constructed of solid surface corian (Color Selection Noted on Approval Drawing). Tray slide mounted at 34” high. Operator shelf to be stainless steel and fold down without tools and mounted at 36” high. Counter provided with 2 Tier FlexiTop designed to hold 4 full size sheet pans and operate as hot or frost top. Counter provided with tempered glass sneezeguard per Delfield drawing. Counter provided with laminate base, standoff panels and LED lighting with sneezeguard and under nosing of counter. Louvers to be powder coated, color noted on Delfield approval drawing. Counter provided on adjustable height casters with stainless steel toe kick on student side and left side.

Serving counter B1 to be a quantity of (1) each and be provided per Delfield SKU 000-20113M0A12 and be 86” wide x 34.62” deep and 36” high. Counter area to be 14 gauge stainless steel surface and have tray slide on student side and work shelf on operator side. Tray slide to be constructed of solid surface corian (Color Selection

Noted on Approval Drawing). Tray slide mounted at 34" high. Operator shelf to be stainless steel and fold down without tools and mounted at 36" high. Counter provided with 1042J built in 5 well, FlexiWell style wells that can operate hot, cold or freeze temperatures. Counter provided with Delfield DCFSFS adjustable style FlexiShield above FlexiWells all per Delfield drawing. Counter provided with laminate base, standoff panels and LED lighting with sneezeguard and under nosing of counter. Louvers to be powder coated, color noted on Delfield approval drawing. Counter provided on adjustable height casters with stainless steel toe kick on student side and left side.

Serving counter B2 to be a quantity of (1) each and be provided per Delfield SKU 000-20113M0A14 and be 86" wide x 34.62" deep and 36" high. Counter area to be 14 gauge stainless steel surface and have tray slide on student side and work shelf on operator side. Tray slide to be constructed of solid surface corian (Color Selection Noted on Approval Drawing). Tray slide mounted at 34" high. Operator shelf to be stainless steel and fold down without tools and mounted at 36" high. Counter provided with 1042J built in 5 well, FlexiWell style wells that can operate hot, cold or freeze temperatures. Counter provided with Delfield DCFSFS adjustable style FlexiShield above FlexiWells all per Delfield drawing. Counter provided with laminate base, standoff panels and LED lighting with sneezeguard and under nosing of counter. Louvers to be powder coated, color noted on Delfield approval drawing. Counter provided on adjustable height casters with stainless steel toe kick on student side and ride side.

Serving counter C1 to be a quantity of (1) each and be provided per Delfield SKU 000-20113M0A1G and be 68" wide x 34.62" deep and 36" high. Counter area to be 14 gauge stainless steel surface and have tray slide on student side and work shelf on operator side. Tray slide to be constructed of solid surface corian (Color Selection Noted on Approval Drawing). Tray slide mounted at 34" high. Operator shelf to be stainless steel and fold down without tools and mounted at 36" high. Counter provided with 3 well Liquitec style cold food pans, flush mount. Counter provided with Delfield DCFSFS adjustable style FlexiShield sneezeguard, constructed of tempered glass LED lights. Counter provided with (4) each 27" refrigerated drawers in base. Drawers to hold 6" deep pans. Counter provided with laminate base, standoff panels and LED lighting with sneezeguard and under nosing of counter. Louvers to be powder coated, color noted on Delfield approval drawing. Counter provided on adjustable height casters with stainless steel toe kick on student side and ride side.

Serving counter C2 to be a quantity of (1) each and be provided per Delfield SKU 000-20113M0A1H and be 73" wide x 34.62" deep and 36" high. Counter area to be 14

gauge stainless steel surface and have tray slide on student side and work shelf on operator side. Tray slide to be constructed of solid surface corian (Color Selection Noted on Approval Drawing). Tray slide mounted at 34" high. Operator shelf to be stainless steel and fold down without tools and mounted at 36" high. Counter provided with 4 well Liquitex style cold food pans, flush mount. Counter provided with Delfield DCFSFS adjustable style FlexiShield sneezeguard, constructed of tempered glass LED lights. Counter provided with (4) each 27" refrigerated drawers and (2) each 19" refrigerated drawers in base. Drawers to hold 6" deep pans. Counter provided with laminate base, standoff panels and LED lighting with sneezeguard and under nosing of counter. Louvers to be powder coated, color noted on Delfield approval drawing. Counter provided on adjustable height casters with stainless steel toe kick on student side and ride side.

Item G1 to be quantity of (2) each cashier stands and be provided per Delfield SKU 000-40013M0A8 with matching construction including laminate base and tray slide constructed of solid surface corian (Color Selection Noted on Approval Drawing). Tray slide mounted on right from student side. Cashier stands provided with NEMA 5-15 plug, toe plates on front and rear with left end returns, adjustable height casters, 3" diameter hole with grommet in top, stainless steel undershelf and cashier drawer.

Item G2 to be quantity of (2) each cashier stands and provided per Delfield SKU 000-40013M0A9 with matching construction including laminate base and tray slide constructed of solid surface corian (Color Selection Noted on Approval Drawing). Tray slide mounted on left from student side. Cashier stands provided with NEMA 5-15 plug, toe plates on front and rear with left end return, adjustable height casters, 3" diameter hole with grommet in top, stainless steel undershelf and cashier drawer.

Item F to be a quantity of (4) each Delfield model NLFACP-8 milk coolers provided per Delfield SKU BS013M0AQ. Milk coolers to be forced air style with 8 milk crate capacity. Milk coolers provided with matching laminate bases noted on approval drawing. Milk coolers also provided with powder coated louvers noted on approval drawing.

Item 11 to be a quantity of (1) each Delfield model SC-36-NU and provided per Delfield SKU 000-40013M0AR with model 1031B, built in N227P ice cream freezer with 12 gallon cabinet capacity. Unit provided with NEMA 5-15 cord and plug, transparent lid for N227P, stainless steel toe plates on all 4 sides and mounted on adjustable height casters.

Item 13 to be a quantity of (1) each Delfield model GAHPT2P-S-IVR, specification line 2 section pass thru heated cabinet. Unit to have full height glass doors on student / cafeteria side and full height solid stainless steel doors on kitchen side. Unit provided with (46) pairs of TS2 tray slides for 18" x 26" sheet pans or 12" x 20" steam table pans.

Item 14 to be a quantity of (2) each Federal Industries model VHSS3678S Vision Series Self Serve heated merchandisers. Units to each be 36" wide x 33" deep x 78" high with square ends. Each unit to have 4 independently controlled heated shelves & removeable stainless steel deck with stainless steel interior and LED interior top lighting. Each unit to have powder coated black bases and tempered glass end inserts. Each unit provided with digital controls and 208-240 volt / 1 phase with NEMA 6-20P cord & plug requiring 13.5 amps. Each unit provided with the following options:

LED lights below shelves, sliding rear access doors, and recessed casters.

Item 15 to be a quantity of (1) each Metro model C569-SDS-UA mobile heated cabinet. Unit to be insulated with solid stainless steel half height doors. Unit provided with top mount, analog controls, ducted heating systems and thermostat from 70 – 200 degrees. Unit provided with 17 sets of universal tray slides for 18" x 26" sheet pans or 12" x 20" steam table pans. Unit provided with casters with NEMA 5-20P cord and plug for 120 volt, 16 amp operation. Unit provided with optional Corner Bumer / Drip Trough.

Bid to include the following options with this Delfield serving counter:

- 1-year parts and labor warranty, 5 year compressor warranty.
- Serving counter provided complete per Delfield Drawing# **1848106_001A**.
- Serving counters provided with cord and plugs noted on drawing.
- KEC to meet with district and CSI to review and provide signed copy of Delfield Drawing to release into production.
- KEC to verify electrical requirements with district and CSI prior to releasing approved drawing.
- CSI to receive all equipment and inspect for any freight damage. If freight damage is present, CSI will file freight claim with KEC and factory. Equipment may not be shipped directly to Grain Valley High School.
- CSI must schedule delivery of equipment in advance with Grain Valley Nutrition Services.
- CSI to mount sneezeguards to all serving counter. Delfield will have counter predrilled for field installation. CSI to uncrate sneezeguard and secure to countertop as part of delivery.
- CSI to mount all tray slides and accessories provided with equipment.

- CSI to deliver all Delfield serving counters, Federal Merchandisers, and Metro heated cabinet to Grain Valley High School. Upon delivery, all equipment must be uncrated, set in place and leveled.
- CSI will make all electrical connections for equipment specified above. This will include hard wire connection for serving counters C1 and C2.
- CSI to start up and equipment and confirm proper operation of all equipment.
- CSI must remove all trash and debris from installation of new serving counter and accessories.

Option 1



NOTE: DO NOT SPLINE
OR INTERLOCK TOGETHER

**-SOLID SURFACE MATERIAL
CORIAN DESIGNER WHITE**

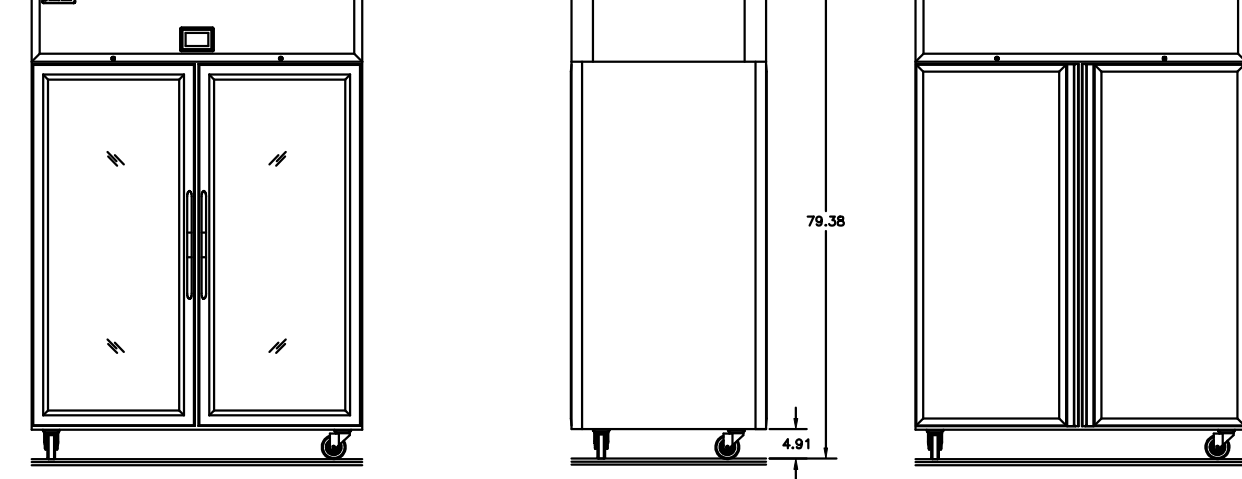
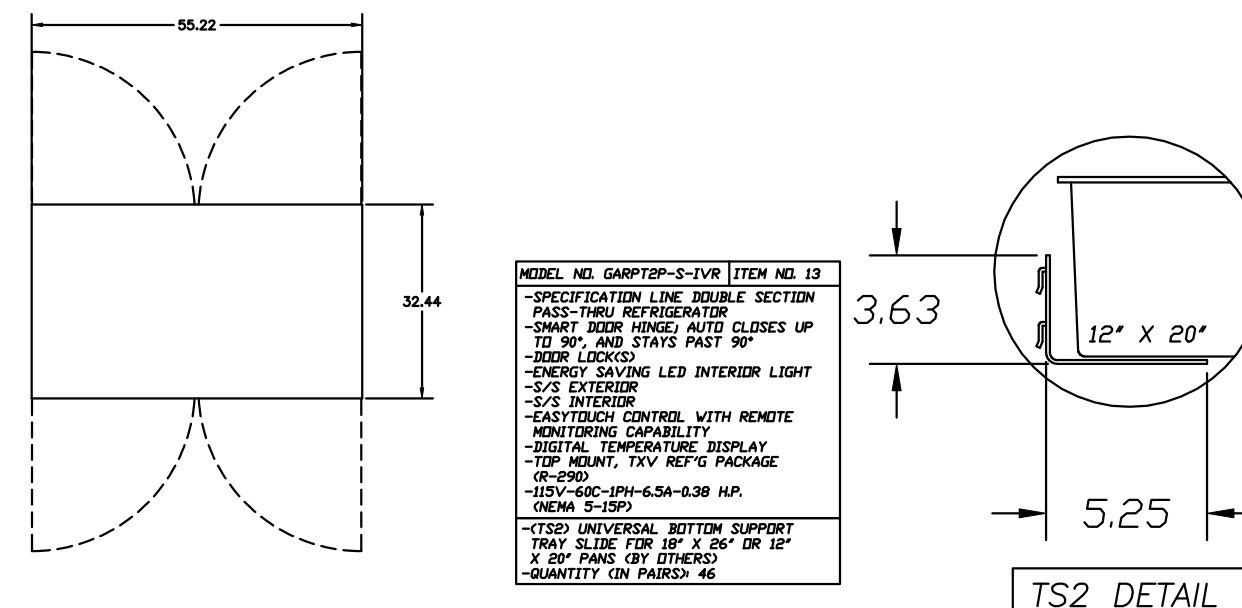
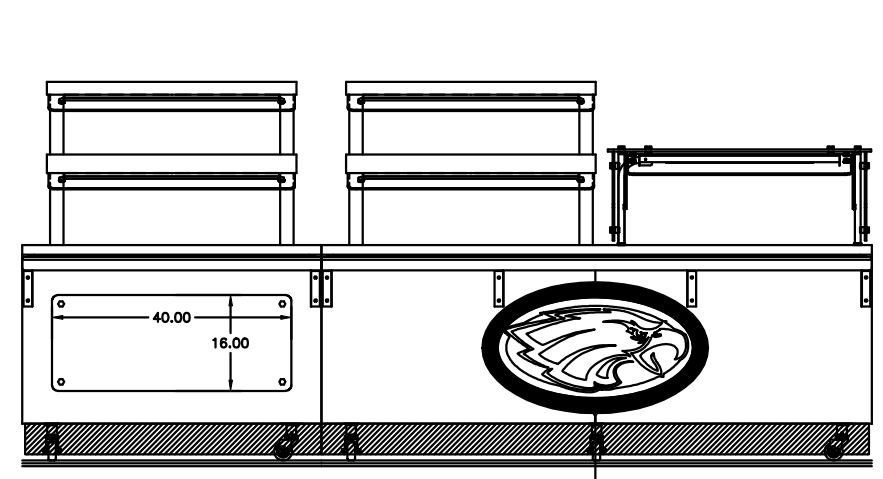
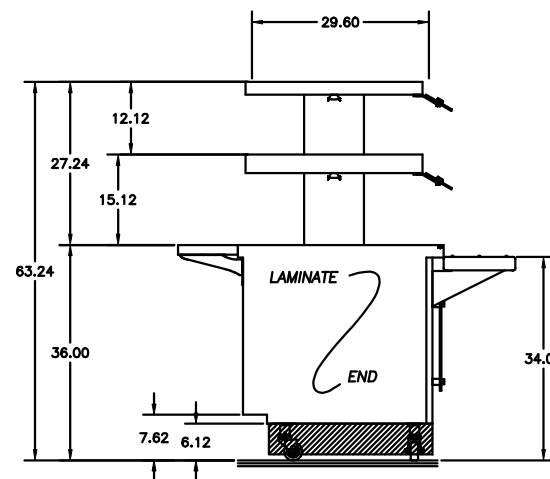
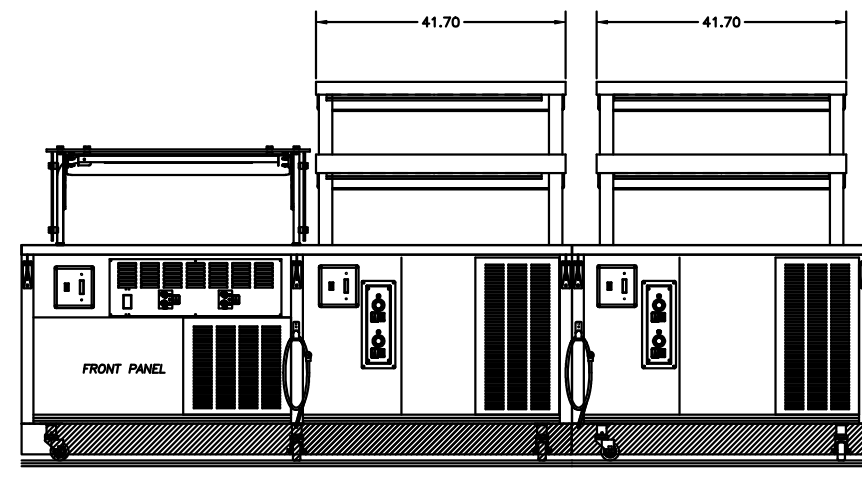
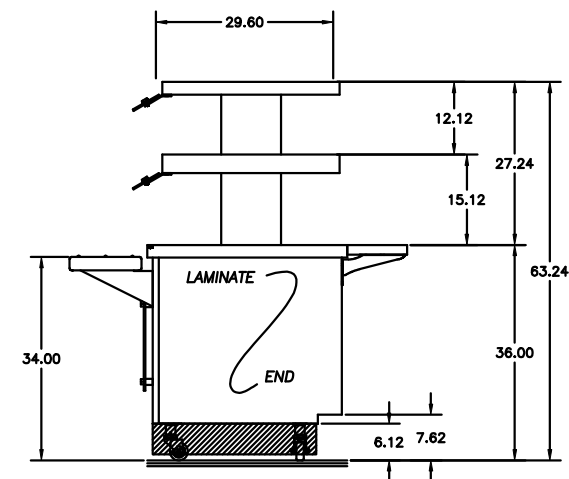
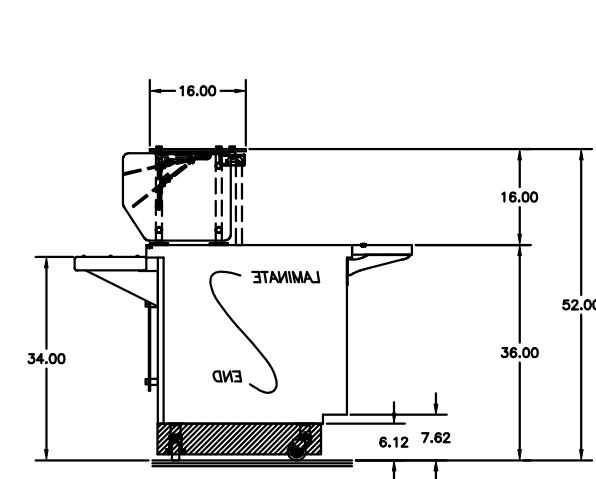
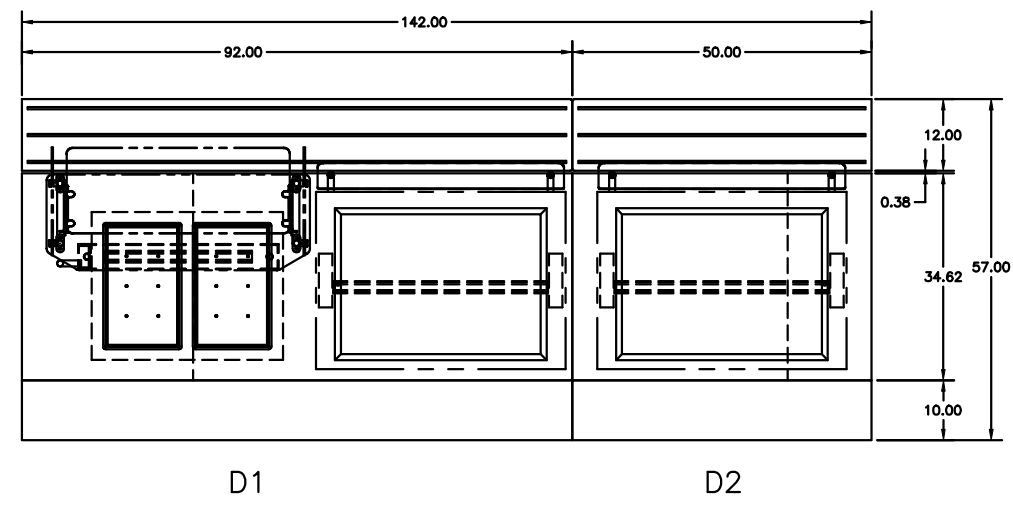

PROVIDE CAFETERIA STYLE TOP WITH REINFORCED PLASTIC LAMINATE BACK
MANUFACTURER: WILSONART
LAMINATE COLOR: 7946-38
GRAIN: VERTICAL

PROVIDE CAFETERIA STYLE TOP WITH REINFORCED PLASTIC LAMINATE BACK
MANUFACTURER: WILSONART
LAMINATE COLOR: 7946-38
GRAIN: VERTICAL

PROVIDE CAFETERIA STYLE TOP WITH REINFORCED PLASTIC LAMINATE BACK
MANUFACTURER: WILSONART
LAMINATE COLOR: 7946-38
GRAIN: VERTICAL

- | | | | |
|--|--|--|--|
| <p>MODEL NO. 800-200-2000H01
ITEM NO. B1
-TOP EXTENSION WITH FRONT PANEL
-MENA NO. 5-15 PLUG WITH SFT CORD
-1/2" HIGH LEVER LOCK PANEL
-BELFIELD FLEXITOP
-BUILT-IN HEAT-RESISTANT HOT AND FROST TOP CONDO
-1/2" HIGH LEVER LOCK PANEL
-3/8" LONG BY 23.38 WIDE TOP
-RECESSED TOP FOR SHEET PAN BY OTHERS
-1/4" SHEET PAN CAPACITY
-FULL ENCLOSED COMPRESSOR
-PROVIDE COATED LOUVERS
-MANNESMANN CONDENSER
-SOLID SURFACE TRAYS/SLIDE WITH RUNNERS
-1/2" CONSTRUCTED WORKSHELF
-MOUNTED ON FOLD-DOWN BRACKETS
-PROVIDE TIE PLATES ON REAR AND LEFT END
-HANGING LED LIGHTS
-GVV-12A4
-1/2" REAR PANELS
-MOUNT UNIT ON 6.12 HIGH CASTERS
-ADJUSTABLE FROM 6-6.812</p> | <p>MODEL NO. 800-200-2000H02
ITEM NO. B2
-SINGLE TIER, SINGLE
-SERVING FLEXIBLE FOOD SHELF
-CONVERTS TO THREE POSITIONS
-SUPPORTS WITH 5/8" FINISH
-AND CHANGING HINGE
-1/2" TEMPERED GLASS FRONT AND ENDS
-1/2" 600 LED LIGHT
-GVV-12A4</p> | <p>MODEL NO. 800-200-2000H03
ITEM NO. B3
-TOP EXTENSION WITH FRONT PANEL
-MENA NO. 5-15 PLUG WITH SFT CORD
-1/2" HIGH LEVER LOCK PANEL
-BELFIELD FLEXITOP
-BUILT-IN HEAT-RESISTANT HOT AND FROST TOP CONDO
-1/2" HIGH LEVER LOCK PANEL
-3/8" LONG BY 23.38 WIDE TOP
-RECESSED TOP FOR SHEET PAN BY OTHERS
-1/4" SHEET PAN CAPACITY
-FULL ENCLOSED COMPRESSOR
-PROVIDE COATED LOUVERS
-MANNESMANN CONDENSER
-SOLID SURFACE TRAYS/SLIDE WITH RUNNERS
-1/2" CONSTRUCTED WORKSHELF
-MOUNTED ON FOLD-DOWN BRACKETS
-PROVIDE TIE PLATES ON REAR AND LEFT END
-HANGING LED LIGHTS
-GVV-12A4
-1/2" REAR PANELS
-MOUNT UNIT ON 6.12 HIGH CASTERS
-ADJUSTABLE FROM 6-6.812</p> | <p>MODEL NO. 800-200-2000H04
ITEM NO. B4
-TOP EXTENSION WITH FRONT PANEL
-MENA NO. 5-15 PLUG WITH SFT CORD
-1/2" HIGH LEVER LOCK PANEL
-BELFIELD FLEXITOP
-BUILT-IN HEAT-RESISTANT HOT AND FROST TOP CONDO
-1/2" HIGH LEVER LOCK PANEL
-3/8" LONG BY 23.38 WIDE TOP
-RECESSED TOP FOR SHEET PAN BY OTHERS
-1/4" SHEET PAN CAPACITY
-FULL ENCLOSED COMPRESSOR
-PROVIDE COATED LOUVERS
-MANNESMANN CONDENSER
-SOLID SURFACE TRAYS/SLIDE WITH RUNNERS
-1/2" CONSTRUCTED WORKSHELF
-MOUNTED ON FOLD-DOWN BRACKETS
-PROVIDE TIE PLATES ON REAR AND LEFT END
-HANGING LED LIGHTS
-GVV-12A4
-1/2" REAR PANELS
-MOUNT UNIT ON 6.12 HIGH CASTERS
-ADJUSTABLE FROM 6-6.812</p> |
|--|--|--|--|

FLEXIWELL UNITS ARE
DRY OPERATION ONLY

NOTE: DO NOT SPLINE
OR INTERLOCK TOGETHER

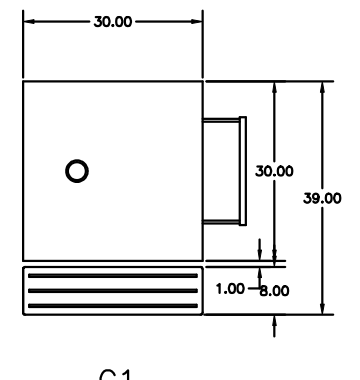
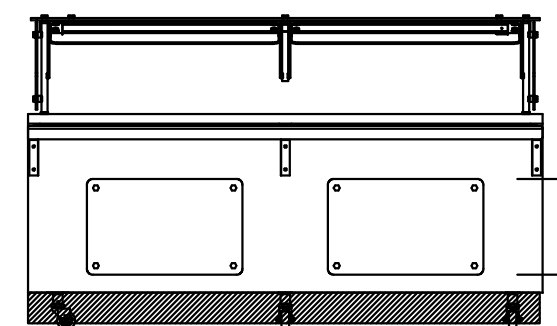
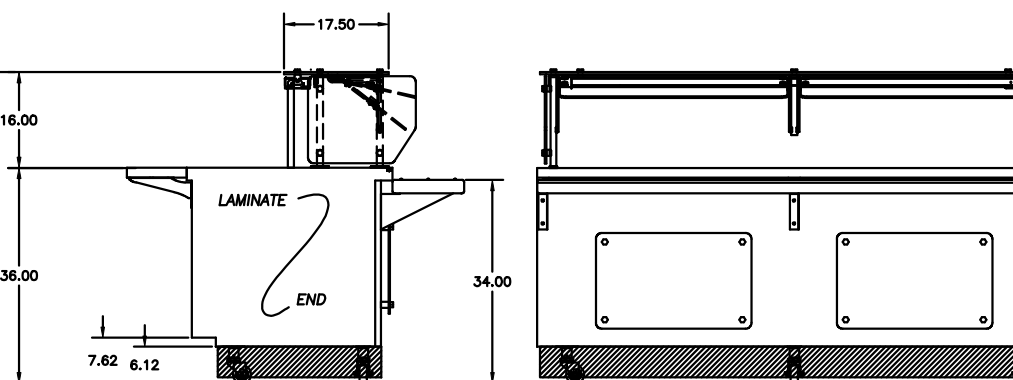
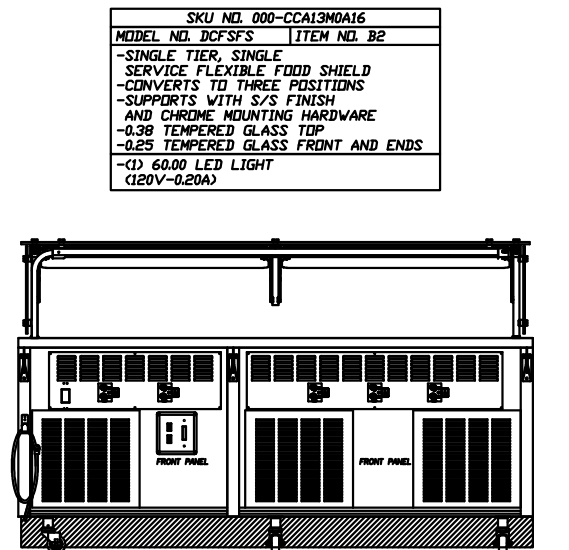
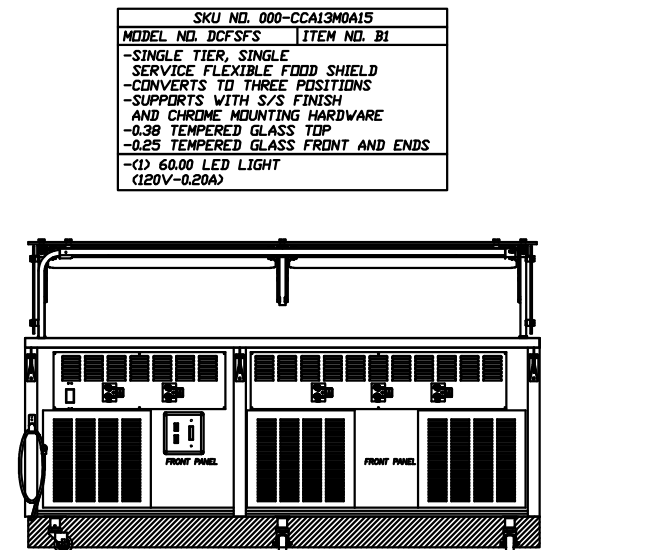
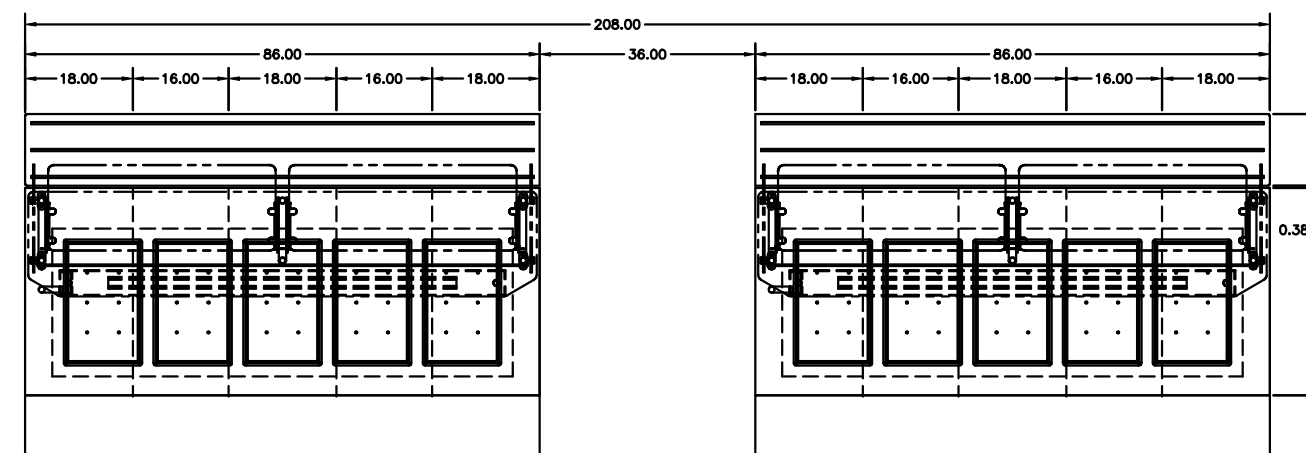

(2) REQUIRED
(1) SHOWN

MODEL NO. 800-400-4000H01
ITEM NO. G1
-CARRIER CENTER
-3 IN DIAMETER HOLE WITH GROOVET
-1/2" SHELF AND LOCKING DRAWER
-1/2" HIGH LEVER LOCK PANEL
-RECEPTACLE MENA #5-15R WITH
-1/2" HIGH LEVER LOCK PANEL
-MENA NO. 5-15 PLUG WITH SFT CORD
-1/2" HIGH LEVER LOCK PANEL
-SOLID SURFACE TRAYS/SLIDE WITH
-RUNNERS
-PROVIDE TIE PLATES ON FRONT AND
-REAR WITH LEFT END RETURN
-MOUNT UNIT ON 6.12 HIGH CASTERS
-ADJUSTABLE FROM 6-6.812

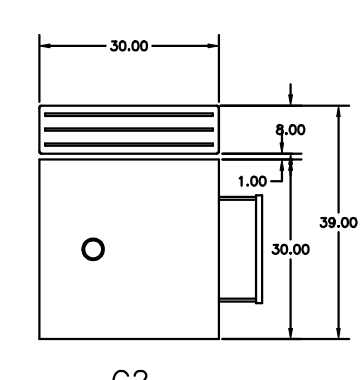

(2) REQUIRED
(1) SHOWN

MODEL NO. 800-400-4000H02
ITEM NO. G2
-CARRIER CENTER
-3 IN DIAMETER HOLE WITH GROOVET
-1/2" SHELF AND LOCKING DRAWER
-1/2" HIGH LEVER LOCK PANEL
-RECEPTACLE MENA #5-15R WITH
-1/2" HIGH LEVER LOCK PANEL
-MENA NO. 5-15 PLUG WITH SFT CORD
-1/2" HIGH LEVER LOCK PANEL
-SOLID SURFACE TRAYS/SLIDE WITH
-RUNNERS
-PROVIDE TIE PLATES ON FRONT AND
-REAR WITH LEFT END RETURN
-MOUNT UNIT ON 6.12 HIGH CASTERS
-ADJUSTABLE FROM 6-6.812

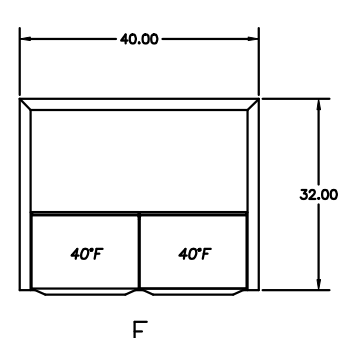
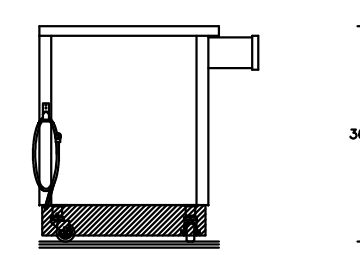
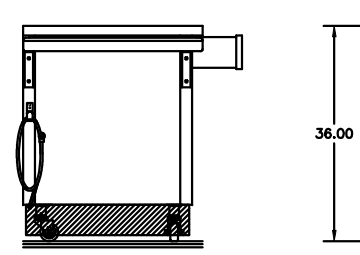

(4) REQUIRED
(1) SHOWN

MODEL NO. 800-400-4000H04
ITEM NO. F
-FREE STANDING MILK OR BEVERAGE
-1/2" STORAGE ONLY
-CAPACITY FOR 2 STANDARD MILK CRATES
-1/2" HIGH LEVER LOCK PANEL
-1/2" HIGH LEVER LOCK PANEL
-1/2" HIGH LEVER LOCK PANEL
-1/2" HIGH LEVER LOCK PANEL
-LAMINATE FINISH ON ALL CO. SIDES

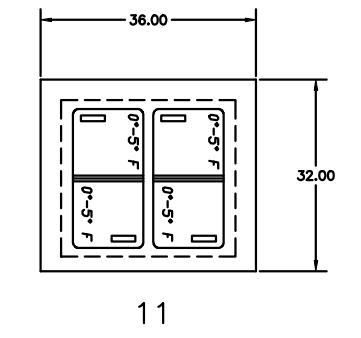
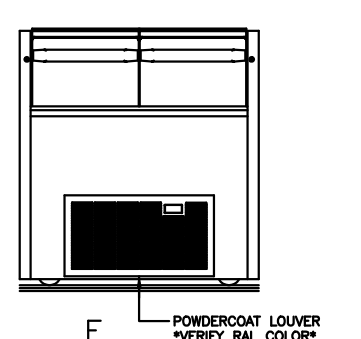

MODEL NO. 800-400-4000H04
ITEM NO. 11
-ALL PURPOSE CARRIER
-BUILT-IN HEAT-RESISTANT HOT AND FROST TOP CONDO
-1/2" HIGH LEVER LOCK PANEL
-RECEPTACLE MENA #5-15R WITH
-1/2" HIGH LEVER LOCK PANEL
-MENA NO. 5-15 PLUG WITH SFT CORD
-1/2" HIGH LEVER LOCK PANEL
-SOLID SURFACE TRAYS/SLIDE WITH
-RUNNERS
-PROVIDE TIE PLATES ON ALL FOUR
-SIDES
-MOUNT UNIT ON 6.12 HIGH CASTERS
-ADJUSTABLE FROM 6-6.812

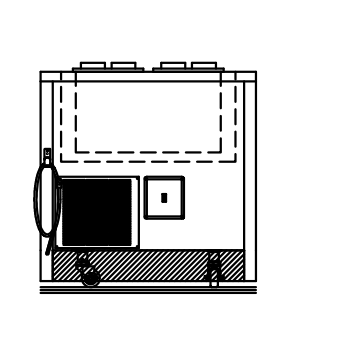

- COMPONENT CRAFTED EQUIPMENT
GENERAL NOTES:
-EXAMINE THIS DRAWING AND RESPOND TO NOTES IF APPLICABLE
-ALL NOTES ARE STANDARD UNLESS OTHERWISE SPECIFIED
- FABRICATION:
-ALL LO-PRO TOPS TO BE 18 GAUGE S/S
-ALL OTHER TOPS TO BE 16 GAUGE S/S WITH 14 GAUGE BRACING
-ALL EQUIPMENT FRONTS TO BE STAINLESS STEEL
-ALL SHELVES TO BE STAINLESS STEEL WITH GALVANIZED
-SUB-BRACING AND DOUBLE HEADING FOR ADDED STRENGTH
-CONSTRUCTION ADHESIVE IS USED ON ALL TOP AND SHELF BRACING
-FOR ADDED STRENGTH AND SOUND DEADENING
-ALL LEGS ARE 6.00" ADJUSTABLE HEIGHT, S/S AND MOUNTED ON
-1.50" LEG RAILS
- VERIFICATION:
-VERIFY SPACING OF SLIDES IN ALL BACK CABINETS
-VERIFY VOLTAGE & AMP RATINGS ON ALL ELECTRICAL OUTLETS
-VERIFY VOLTAGE REQUIRED ON HOT FOOD TABLES, LIGHTS, ETC.
-VERIFY MANUFACTURER ELECTRICAL AND INSTALLATION REQUIREMENTS
-OF ALL DISPENSERS, DROP-IN, ROLL WARMERS, ETC.
-WHEN PLACING DISPENSERS IN TOP EXTENSIONS ONLY, ORDER
-DISPENSERS NO LONGER THAN 28.00"
- ELECTRICAL:
-ALL FIELD WIRING JUNCTION BOXES ARE LOCATED SO THE BOXES
-CAN BE EXAMINED FROM THE FRONT SIDE OF THE COUNTER, AND
-THE CONNECTIONS CAN BE EXAMINED WITHOUT DISTURBING THE
-WIRING OF THE APPLIANCE
-ALL 120 VOLT RECEPTACLES (15 AND 20 AMP) WILL BE GFCI
-PROTECTED DUPLEXES
-ALL LINE-UPS WILL BE HARDWIRED IN FIELD
- REMOTE REFRIGERATION:
-REMOTE REFRIGERATORS ARE SUPPLIED WITH EXPANSION VALVE,
-SOLENOID VALVE, AND THERMOSTAT
-REMOTE FREEZERS ARE SUPPLIED WITH EXPANSION VALVE,
-SOLENOID VALVE, THERMOSTAT, AND DEFROST TIMER
-ALL OTHER CONTROLS ARE SUPPLIED BY OTHERS
-DROP-IN COLD PANS ARE SUPPLIED WITH EXPANSION VALVE AND
-COURTESY PROBE TUBE
- OVERSTRUCTURE-HEATLAMP:
-SHELF HEIGHTS OF 18" RECOMMENDED TO ALLOW MINIMUM 14"
-CLEARANCE BETWEEN HEATLAMPS AND SHELF BELOW
-ALL HANGING HEATLAMPS MUST MEET MINIMUM 14" CLEARANCE
-BETWEEN HEATLAMP AND TOP SHELF
- ENVIRONMENTALLY FRIENDLY INSULATION:
-KYOTO PROTOCOL COMPLIANT
-NON O.D.P. (OZONE DEPLETION POTENTIAL)
-NON G.W.P. (GLOBAL WARMING POTENTIAL)
-POLYURETHANE INSULATION
- BASE LAMINATE INFO
* MANUFACTURER: WILSONART
* MODEL: 7946-38
* FINISH: FINE VELVET
* DESCRIPTION: BRAZILWOOD
* GRAIN: VERTICAL

APPROVED FOR FABRICATION
 APPROVED
 APPROVED AS NOTED
 RESUBMIT
COMPANY: _____ DATE: _____

If you are placing equipment into an area which has certain
wooden or other floor tops normally accepted in the
food - service industry (NSF, UL, etc.) Deifield must be
notified of these specifications in detail before installation of
the equipment in order that we may quote additional costs
if any. Failure to notify Deifield Company before fabrica-
tion releases us from any obligation to modify our standards
without any additional charge.

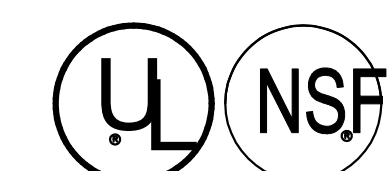

Shelleysteel

- NOTES:
* TOPS ARE TO BE 14 GAUGE S/S
* PROVIDE INTERLOCKS AS REQUIRED
* ALL STANDARD LOCKING POLYURETHANE CASTERS
* CORDS STANDARD WITH 90° PLUGS
* UNITS SPECIFIED WITH DRAINS TO HAVE GATE VALVE
AND GARDEN HOSE HOOK UP
* WHEN TRAY SLIDE/WORK SHELF BRACKETS ARE USED:
FOLD DOWN BRACKETS ARE STANDARD UNLESS
OTHERWISE REQUESTED
* ALL 120 VOLT RECEPTACLES (15 AND 20 AMP) WILL BE
GFCI PROTECTED DUPLEXES
- ENVIRONMENTALLY FRIENDLY INSULATION
* NON O.D.P. (OZONE DEPLETION POTENTIAL)
* NON G.W.P. (GLOBAL WARMING POTENTIAL)
* POLYURETHANE INSULATION

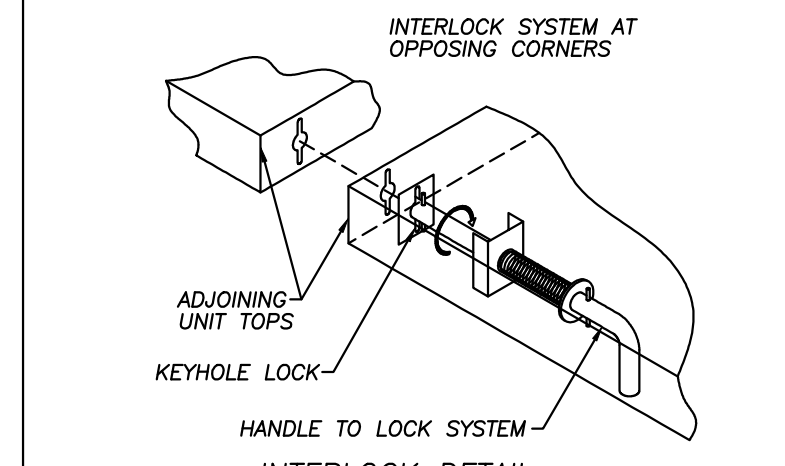

- INTERLOCK SYSTEM AT
OPPOSING CORNERS
- KEYHOLE LOCK
- HANDLE TO LOCK SYSTEM
- INTERLOCK DETAIL
- BASE LAMINATE INFO
* MANUFACTURER: WILSONART
* MODEL: 7946-38
* FINISH: FINE VELVET
* DESCRIPTION: BRAZILWOOD
* GRAIN: VERTICAL
- DECOR PANEL LAMINATE INFO
* MANUFACTURER: FORMICA
* MODEL: 949-58
* FINISH: MATTE
* DESCRIPTION: WHITE



— BASE LAMINATE INFO
 * MANUFACTURER: WILSONART
 * MODEL: 7946-38
 * FINISH: FINE VELVET
 * DESCRIPTION: BRAZILWOOD
 * GRAIN: VERTICAL

— DECOR PANEL LAMINATE INFO
 * MANUFACTURER: FORMICA
 * MODEL: 949-58
 * FINISH: MATTE
 * DESCRIPTION: WHITE

PROVIDE ALL UNITS WITH 14 GA. S/S TOPS

COMPONENT CRAFTED CUSTOM EQUIPMENT GENERAL NOTES:
 —EXAMINE THIS DRAWING AND RESPOND TO NOTES IF APPLICABLE
 —ALL NOTES ARE STANDARD UNLESS OTHERWISE SPECIFIED

FABRICATION:
 —ALL LO-PRO TOPS TO BE 18 GAUGE S/S
 —ALL OTHER TOPS TO BE 16 GAUGE S/S WITH 14 GAUGE BRACING
 —ALL EQUIPMENT FRONTS TO BE STAINLESS STEEL
 —ALL SHELVES TO BE STAINLESS STEEL WITH GALVANIZED SUB-BRACING AND DOUBLE HEADING WISING FOR ADDED STRENGTH
 —CONSTRUCTION ADHESIVE IS USED ON ALL TOP AND SHELF BRACING FOR ADDED STRENGTH AND SOUND DEADENING
 —ALL LEGS ARE 6.00" ADJUSTABLE HEIGHT, S/S AND MOUNTED ON 1.50" LEG RAILS

VERIFICATION:
 —VERIFY SPACING OF SLIDES IN ALL RACK CABINETS
 —VERIFY VOLTAGE & AMP RATINGS ON ALL ELECTRICAL OUTLETS
 —VERIFY VOLTAGE REQUIRED ON HOT FOOD TABLES, LIGHTS, ETC.
 —VERIFY MAKE/MODEL ELECTRICAL AND INSTALLATION REQUIREMENTS OF ALL DISPENSERS, DROP-IN, ROLL WARMERS, ETC.
 —WHEN PLACING DISPENSERS IN TOP EXTENSIONS ONLY, ORDER DISPENSERS NO LONGER THAN 28.00"

ELECTRICAL:
 —ALL FIELD WIRING JUNCTION BOXES ARE LOCATED SO THE BOXES CAN BE EXAMINED FROM THE FRONT SIDE OF THE COUNTER, AND THE CONNECTIONS CAN BE EXAMINED WITHOUT DISTURBING THE WIRING OF THE APPLIANCE
 —ALL 120 VOLT RECEPTACLES (15 AND 20 AMP) WILL BE GFCI PROTECTED DUPLEX
 —ALL LINE-UPS WILL BE HARDWIRED IN FIELD

REMOTE REFRIGERATIONS:
 —REMOTE REFRIGERATORS ARE SUPPLIED WITH EXPANSION VALVE, SOLENOID VALVE, AND THERMOSTAT
 —REMOTE FREEZERS ARE SUPPLIED WITH EXPANSION VALVE, SOLENOID VALVE, THERMOSTAT, AND DEFOST TIMER
 —ALL OTHER CONTROLS ARE SUPPLIED BY OTHERS
 —DROP-IN COLD PANS ARE SUPPLIED WITH EXPANSION VALVE AND COURTESY PROBE TUBE

OVERSTRUCTURE-HEATLAMP:
 —SHELF HEIGHTS OF 19" RECOMMENDED TO ALLOW MINIMUM 14" CLEARANCE BETWEEN HEATLAMPS AND SHELF BELOW
 —ALL HANGING HEATLAMPS MUST MEET MINIMUM 14" CLEARANCE BETWEEN HEATLAMP AND TOP SHELF

ENVIRONMENTALLY-FRIENDLY INSULATION:
 —KYOTO PROTOCOL COMPLIANT
 —NON G.O.P. (ODINE DEPLETION POTENTIAL)
 —NON G.W.P. (GLOBAL WARMING POTENTIAL)
 —POLYURETHANE INSULATION

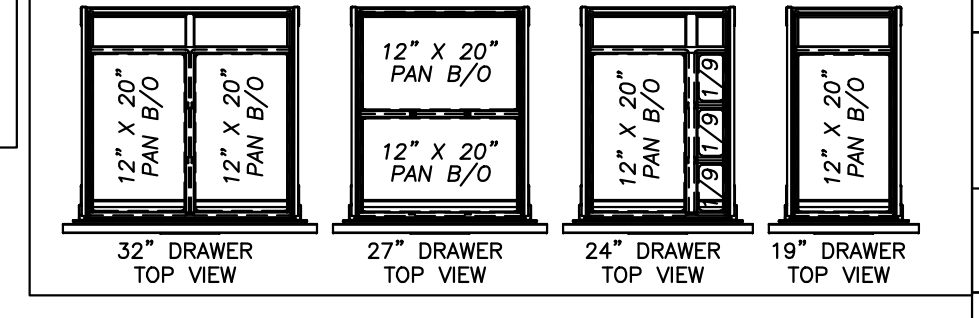

DATE	BY	REVISIONS	DATE	BY	REVISIONS
1/22/24	JD	6	1/22/24	JD	6
3/11/24	JD	7	3/11/24	JD	7
10/4/23	JD	8	10/4/23	JD	8
10/26/23	JD	9	10/26/23	JD	9
11/10/23	JD	10	11/10/23	JD	10

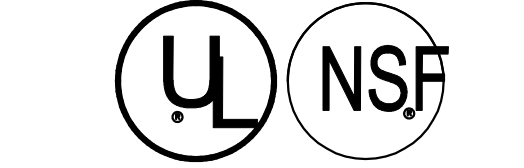

APPROVED FOR FABRICATION

APPROVED
 APPROVED AS NOTED
 RESUBMIT

COMPANY: _____
 BY: _____ DATE: _____

If you are placing equipment into an area which has certain standards or codes other than those normally accepted in the food service industry (NSF, UL, etc.) Delfield must be notified in order that we may quote additional costs if any. Failure to notify the Delfield Company before fabrication release us from any obligation to modify our standards without any additional charges.

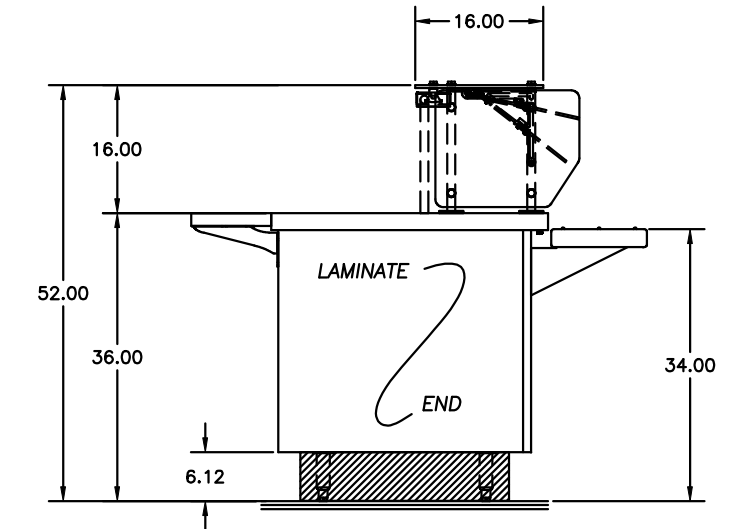
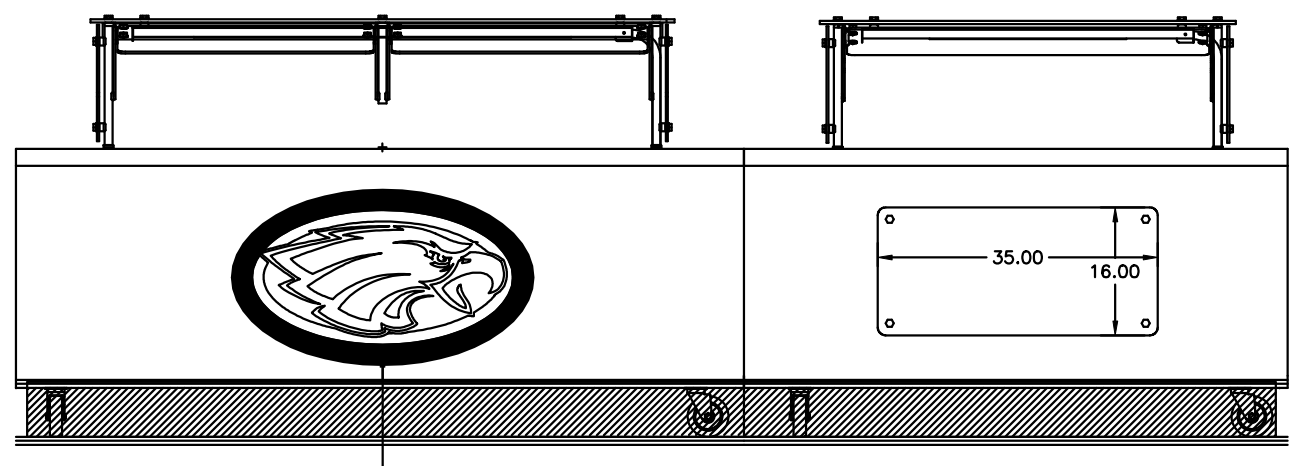
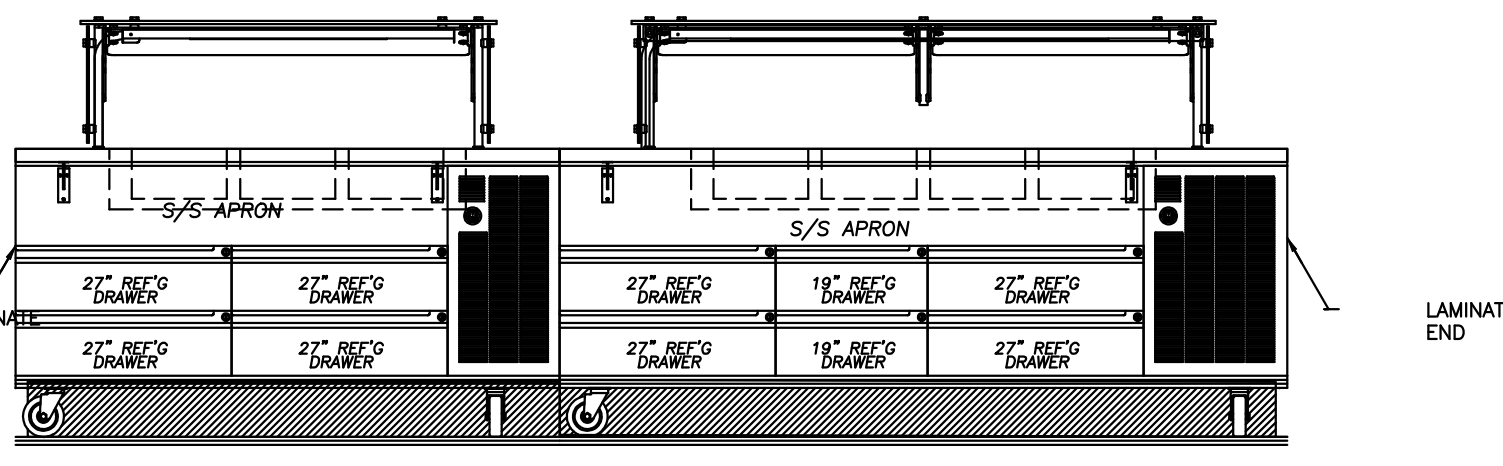
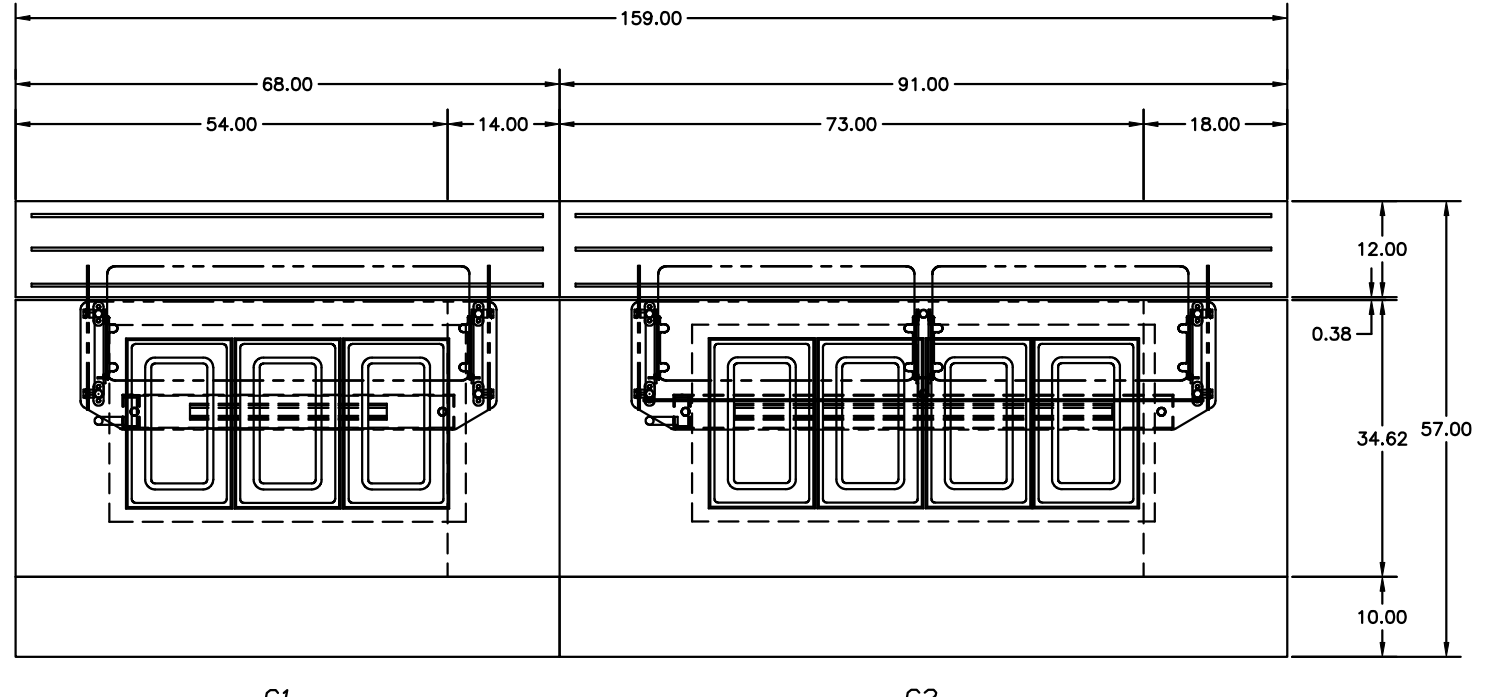

—PROVIDE CAFETERIA STYLE TOP WITH REINFORCED PLASTIC LAMINATE BACK
 * MANUFACTURER: WILSON ART
 * LAMINATE COLOR: 7946-38 BRAZILWOOD

PROVIDE LAMINATE FINISH FRONTS ON ALL SURFACES; DOORS, DRAWERS, S/S APRONS, BRACKET PANELS

SKU NO. 000-20113M0A1G
 MODEL NO. 18MCSBP ITEM NO. C1

—SELF CONTAINED REF'G MEGA TOP WORK TABLE
 —C9 FULL SIZE LIQUIDATED OPTION
 —PROVIDE DRAWER LOCK(S)
 —DRAWERS TO HOLD 6" DEEP PANS
 —ADAPTER BARS BY OTHERS
 —HINGED REMOVABLE COVER
 —2.00" DIA. HOLE FOR ACCESS TO POWER SWITCH IN LOUVERED PANEL
 —33"X-41" STORAGE IN TOP OPENING(S)
 —36"X-40" STORAGE IN BASE
 —115V-60C-1PH-8A-1/2HP
 —REF'G PACKAGE, REFR
 —BASE PROVIDED WITH EXPANSION VALVE, SOLENOID VALVE, AND THERMOSTATIC CONTROL
 —COLD PAN PROVIDED WITH EXPANSION VALVE, PRESSURE CONTROL, AND SOLENOID VALVE WITH ON/OFF SWITCH
 —COMPRESSOR INTAKE SHROUD
 —REAR LOUVER OMITTED
 —S/S CONSTRUCTED WORKSHELF
 —MOUNTED ON FIXED BRACKETS
 —SOLID SURFACE TRAYS/SLIDE WITH RUNNERS
 —MOUNT UNIT ON 6.12 HIGH CASTERS
 —S/S KICK PLATE AT REAR WITH LEFT END RETURN
 —UNDERMOUNTING LED LIGHTS (120V-12A)
 —(C) DECOR PANELS

SKU NO. 000-20113M0A1H
 MODEL NO. 18MCSBP ITEM NO. C2

—SELF CONTAINED REF'G MEGA TOP WORK TABLE
 —C9 FULL SIZE LIQUIDATED OPTION
 —PROVIDE DRAWER LOCK(S)
 —DRAWERS TO HOLD 6" DEEP PANS
 —ADAPTER BARS BY OTHERS
 —HINGED REMOVABLE COVER
 —2.00" DIA. HOLE FOR ACCESS TO POWER SWITCH IN LOUVERED PANEL
 —33"X-41" STORAGE IN TOP OPENING(S)
 —36"X-40" STORAGE IN BASE
 —115V-60C-1PH-8A-1/2HP & 1/2HP
 —REF'G PACKAGE, REFR
 —BASE PROVIDED WITH EXPANSION VALVE, SOLENOID VALVE, AND THERMOSTATIC CONTROL
 —COLD PAN PROVIDED WITH EXPANSION VALVE, PRESSURE CONTROL, AND SOLENOID VALVE WITH ON/OFF SWITCH
 —COMPRESSOR INTAKE SHROUD
 —REAR LOUVER OMITTED
 —S/S CONSTRUCTED WORKSHELF
 —MOUNTED ON FIXED BRACKETS
 —SOLID SURFACE TRAYS/SLIDE WITH RUNNERS
 —MOUNT UNIT ON 6.12 HIGH CASTERS
 —S/S KICK PLATE AT REAR WITH LEFT END RETURN
 —UNDERMOUNTING LED LIGHTS (120V-12A)
 —(C) DECOR PANELS

SKU NO. 000-CCAI3M0A0N
 MODEL NO. 18CFS S [C1]

—SINGLE TIER, SINGLE SERVICE FLEXIBLE FOOD SHIELD
 —CONVERTS TO THREE POSITIONS
 —SUPPORTS WITH S/S FINISH AND MOUNTING HARDWARE
 —0.38 TEMPERED GLASS TOP
 —0.25 TEMPERED GLASS FRONT AND ENDS
 —(C) 24.00 LED LIGHT (120V-016A)

SKU NO. 000-CCAI3M0A0D
 MODEL NO. 18CFS S [C2]

—SINGLE TIER, SINGLE SERVICE FLEXIBLE FOOD SHIELD
 —CONVERTS TO THREE POSITIONS
 —SUPPORTS WITH S/S FINISH AND MOUNTING HARDWARE
 —0.38 TEMPERED GLASS TOP
 —0.25 TEMPERED GLASS FRONT AND ENDS
 —(C) 48.00 LED LIGHT (120V-016A)

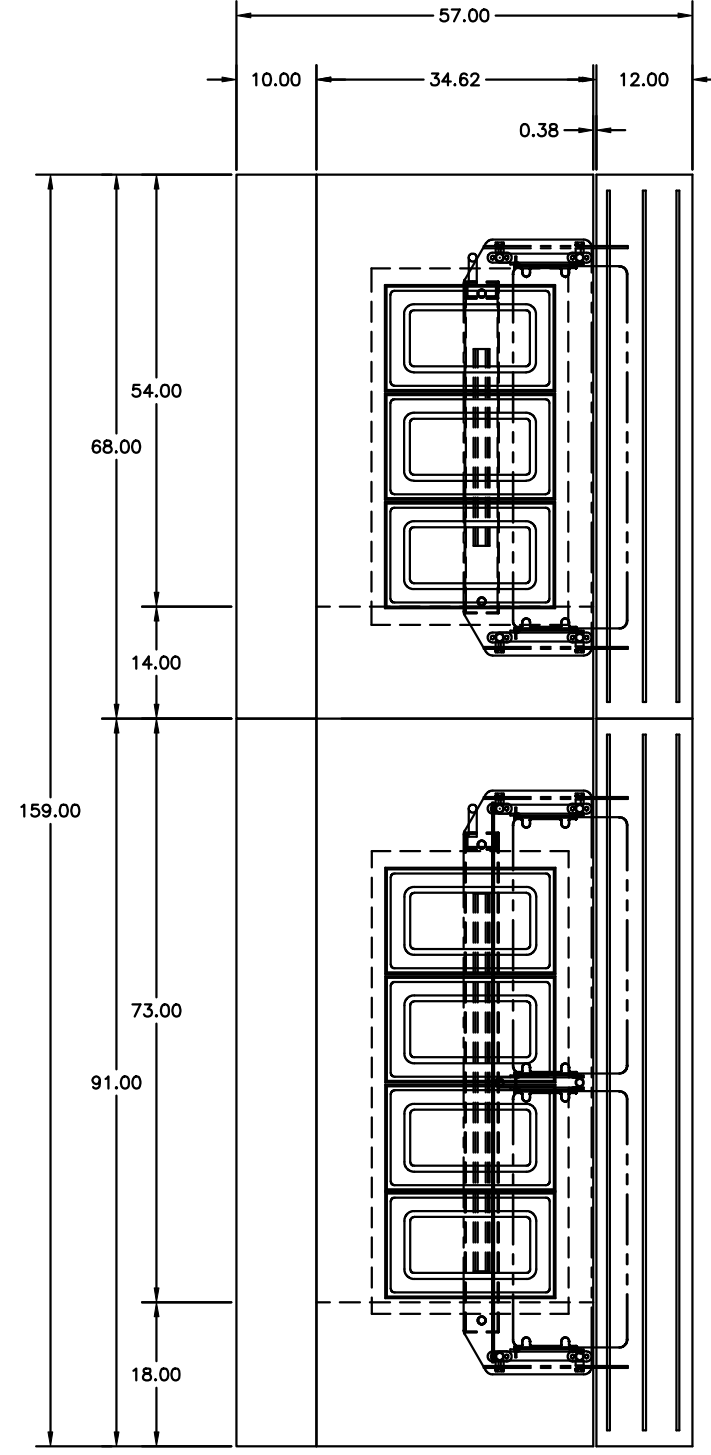

C1

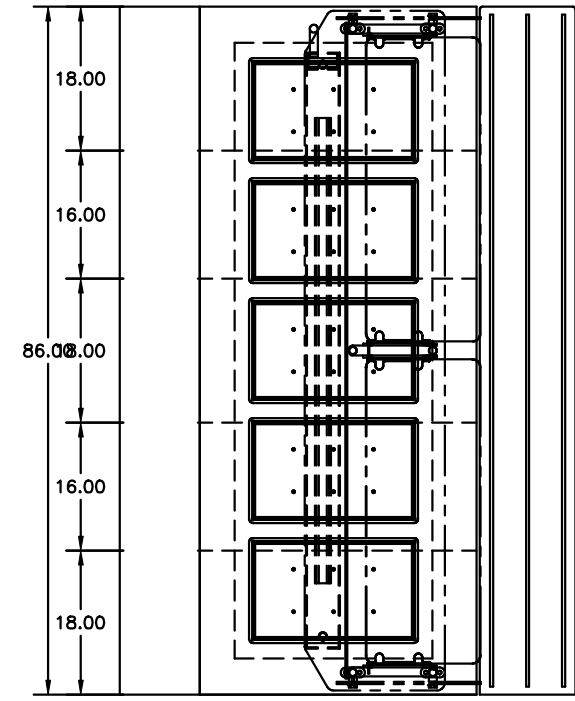

B1

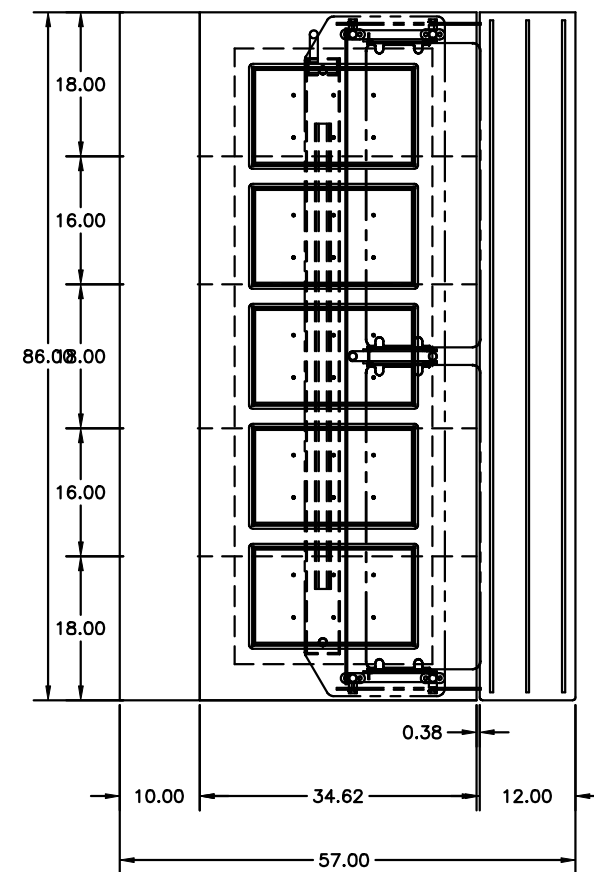

B2

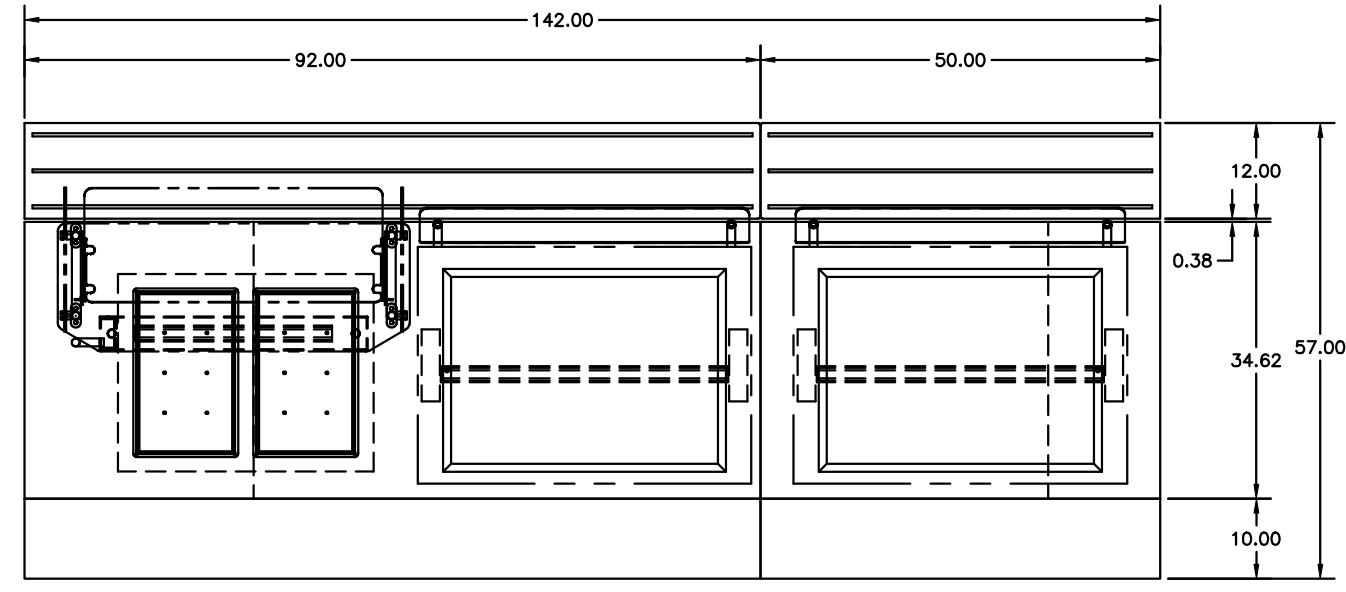

C2

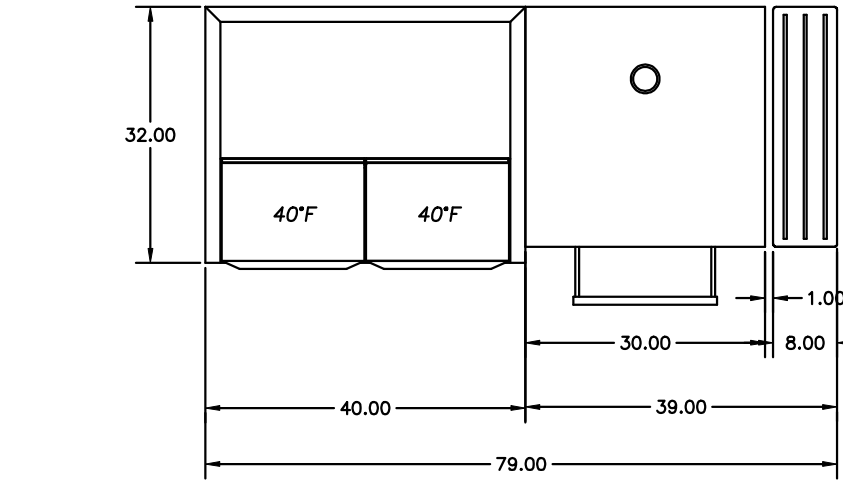
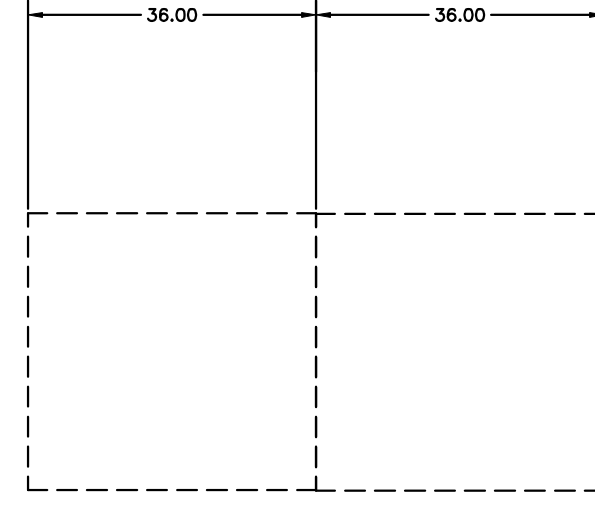

F G2

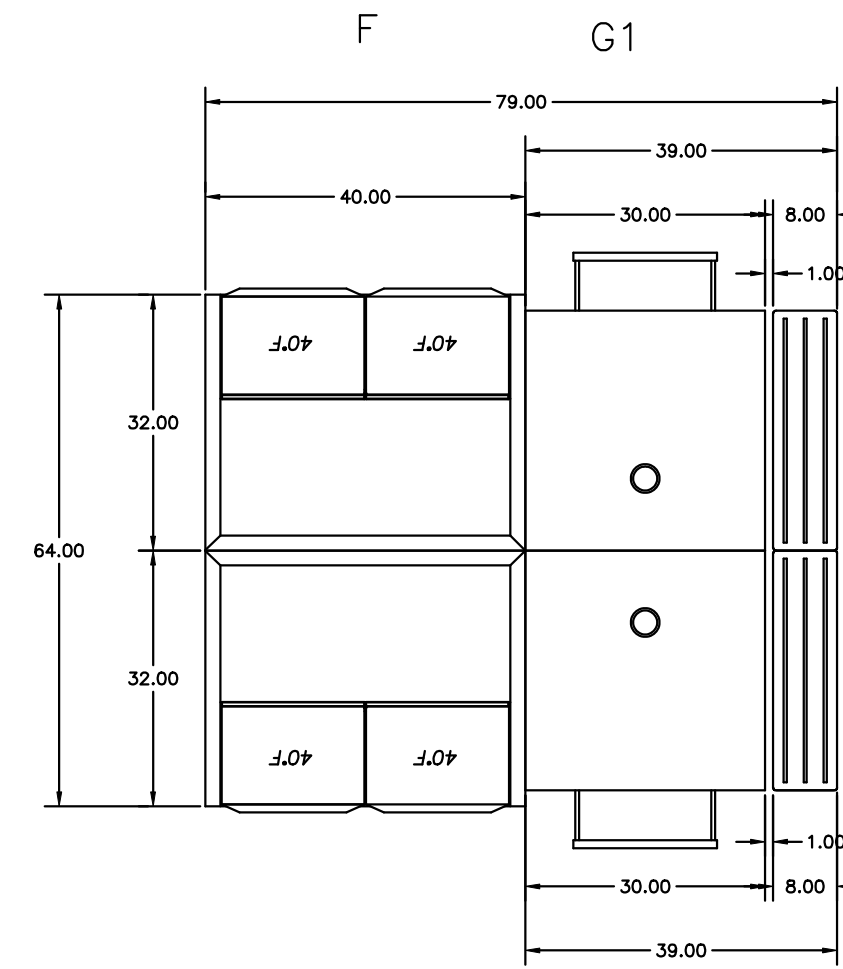

F G2

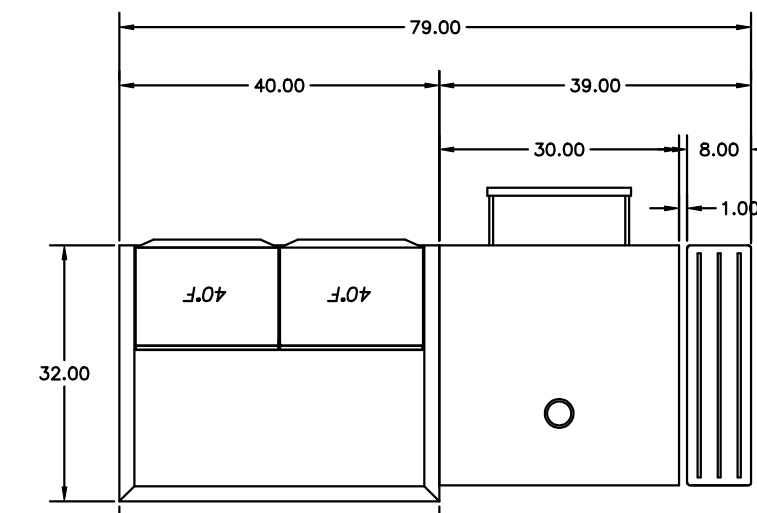

F G1

SHEET NUMBER: **3_01_3**
 DRAWN BY: **CL**
 APPROVED BY: **B. LYBBER**
 DRAWING NUMBER: **1848106_003A**
 DATE: **7/25/23**
 SCALE: **1/2" = 1'-0"**

Delfield
 VERB SITE @ WWW.DELFIELD.COM
 980 S. ISABELLA RD.
 MT. PLEASANT, MT 48858
 (989) 773-7981 • 800-733-8821
 THIS DRAWING IS THE PROPERTY
 OF DELFIELD. IT IS NOT TO BE
 USED OR REPRODUCED WITHOUT
 THE EXPRESS WRITTEN
 CONSENT OF DELFIELD.

JOB NAME:
GRAIN VALLEY HIGH SCHOOL
 DEALER:

NO. REVISIONS	DATE	BY	NO. REVISIONS	DATE	BY
6			6		
7			7		
8			8		
9			9		
10			10		